



SGM802

Low-Power, SC70/SOT μ P Reset Circuit with Capacitor-Adjustable Reset Timeout Delay

GENERAL DESCRIPTION

The SGM802 low-power micro-processor supervisor circuit monitors system voltages from 1.6V to 5V. This device performs a single function: it asserts a reset signal whenever the V_{CC} supply voltage falls below its reset threshold. The reset output remains asserted for the reset timeout period after V_{CC} rises above the reset threshold. The reset timeout is externally set by a capacitor to provide more flexibility.

The SGM802 has an active-high, push-pull reset output. It is available in Green SC70-4 (R) and SOT-143 packages. The SGM802 is specified over an ambient temperature range of -40°C to $+85^{\circ}\text{C}$.

FEATURES

- Monitor System Voltages from 1.6V to 5V
- Capacitor-Adjustable Reset Timeout Period
- Low Quiescent Current ($3\mu\text{A}$ TYP)
- Push-Pull RESET Output Option
- Guaranteed RESET Valid to $V_{CC} = 1\text{V}$
- Immune to Short V_{CC} Transients
- Available in Green SC70-4 (R) and SOT-143 Packages

APPLICATIONS

Portable Equipment
Battery-Powered Computers/Controllers
Automotive
Medical Equipment
Intelligent Instruments
Embedded Controllers
Critical μ P Monitoring
Set-Top Boxes
Computers

TYPICAL APPLICATION

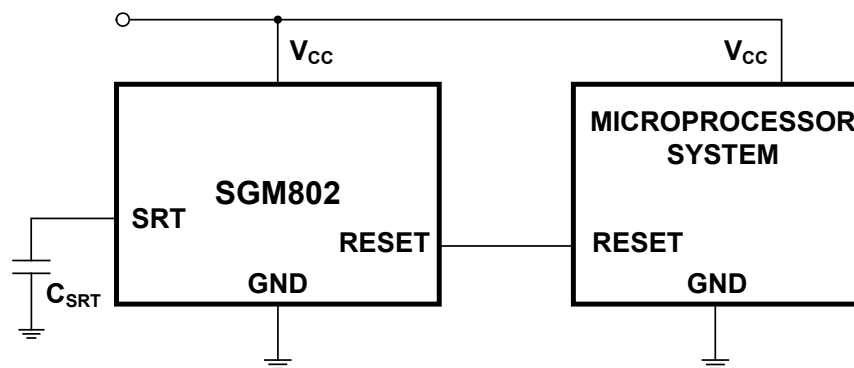

PACKAGE/ORDERING INFORMATION

MODEL	PIN-PACKAGE	RESET THRESHOLD (TYP)	ORDERING NUMBER	PACKAGE MARKING	PACKING OPTION
SGM802	SOT-143	1.63V	SGM802-1.63YKA4G/TR	S78XX	Tape and Reel, 3000
		2.32V	SGM802-2.32YKA4G/TR	S79XX	Tape and Reel, 3000
		2.63V	SGM802-2.63YKA4G/TR	S7AXX	Tape and Reel, 3000
		2.93V	SGM802-2.93YKA4G/TR	S7BXX	Tape and Reel, 3000
	SC70-4 (R)	1.63V	SGM802-1.63YC4G/TR	S7DXX	Tape and Reel, 3000
		2.32V	SGM802-2.32YC4G/TR	S7EXX	Tape and Reel, 3000
		2.63V	SGM802-2.63YC4G/TR	S7FXX	Tape and Reel, 3000
		2.93V	SGM802-2.93YC4G/TR	S80XX	Tape and Reel, 3000

NOTE: XX = Date Code.

Green (RoHS & HSF): SG Micro Corp defines "Green" to mean Pb-Free (RoHS compatible) and free of halogen substances. If you have additional comments or questions, please contact your SGMICRO representative directly.

MARKING INFORMATION

SYY X X

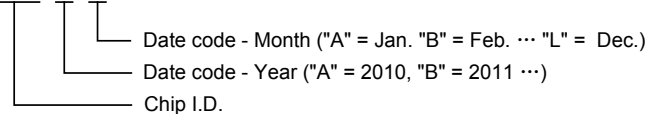

For example: S78BA (2011, January)

ABSOLUTE MAXIMUM RATINGS

All Voltages Referenced to GND

V _{CC}	-0.3V to 6V
SRT, RESET (Push-Pull).....	-0.3V to (V _{CC} + 0.3V)
Input Current (All Pins).....	20mA
Output Current (RESET)	20mA
Operating Temperature Range	-40°C to +85°C
Storage Temperature Range	-65°C to +150°C
Junction Temperature.....	150°C
Lead Temperature (Soldering, 10s)	260°C
ESD Susceptibility	
HBM.....	3000V
MM.....	300V

NOTE:

Stresses beyond those listed under "Absolute Maximum Ratings" may cause permanent damage to the device. These are stress ratings only, and functional operation of the device at these or any other conditions beyond those indicated in the operational sections of the specifications is not implied. Exposure to absolute maximum rating conditions for extended periods may affect device reliability.

CAUTION

This integrated circuit can be damaged by ESD if you don't pay attention to ESD protection. SGMICRO recommends that all integrated circuits be handled with appropriate precautions. Failure to observe proper handling and installation procedures can cause damage. ESD damage can range from subtle performance degradation to complete device failure. Precision integrated circuits may be more susceptible to damage because very small parametric changes could cause the device not to meet its published specifications.

SGMICRO reserves the right to make any change in circuit design, specification or other related things if necessary without notice at any time. Please contact SGMICRO sales office to get the latest datasheet.

PIN CONFIGURATIONS (TOP VIEW)

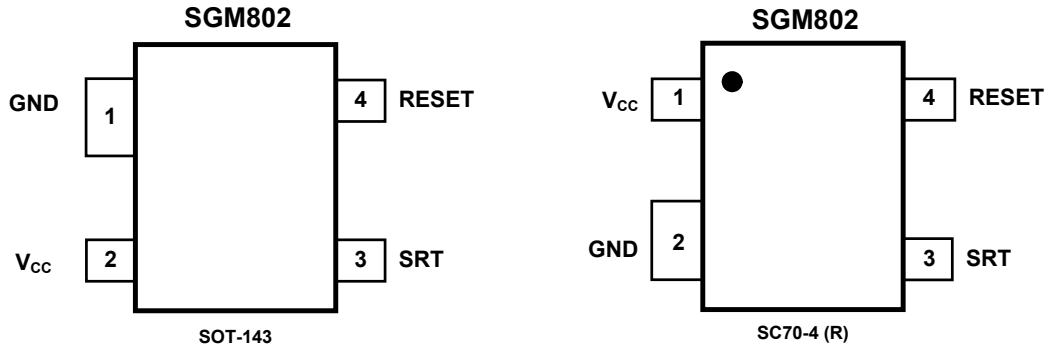

PIN DESCRIPTION

PIN		NAME	FUNCTION
SOT-143	SC70-4 (R)		
1	2	GND	Ground.
2	1	V _{CC}	Supply Voltage and Reset Threshold Monitor Input.
3	3	SRT	Set Reset Timeout Input. Connect a capacitor between SRT and ground to set the timeout period. Determine the period as follows: $t_{RP} = 2.6 \times 10^6 \times C_{SRT} + 340 \times 10^{-6}$ with t_{RP} in seconds and C_{SRT} in farads.
4	4	RESET	RESET changes from low to high whenever V _{CC} drops below the selected reset threshold voltage. RESET remains high for the reset timeout period after V _{CC} exceeds the reset threshold.

ELECTRICAL CHARACTERISTICS(V_{CC} = 1V to 5.5V, T_A = -40°C to +85°C, typical values are at V_{CC} = 5V and T_A = +25°C, unless otherwise specified.)

PARAMETER	SYMBOL	CONDITIONS	MIN	TYP	MAX	UNITS
Supply Voltage Range	V _{CC}		1.0		5.5	V
Supply Current	I _{CC}	V _{CC} ≤ 5.0V		3.9	7.0	μA
		V _{CC} ≤ 3.3V		3.4	5.5	
		V _{CC} ≤ 2.0V		3.0	4.8	
V _{CC} Reset Threshold Accuracy	V _{TH}	T _A = +25°C	V _{TH} - 2.5%		V _{TH} + 2.5%	V
		T _A = -40°C to +85°C	V _{TH} - 3.5%		V _{TH} + 3.5%	
Hysteresis	V _{HYST}			4 × V _{TH}		mV
V _{CC} to Reset Delay	t _{RD}	V _{CC} falling at 1mV/μs		80		μs
Reset Timeout Period	t _{RP}	C _{SRT} = 1500pF	3.00	4.25	5.75	ms
		C _{SRT} = 0		0.34		
V _{SRT} Ramp Current	I _{RAMP}	V _{SRT} = 0 to 0.65V, V _{CC} = 1.6V to 5V		210		nA
V _{SRT} Ramp Threshold	V _{TH-RAMP}	V _{CC} = 1.6V to 5V (V _{RAMP} rising)		0.6		V
RESET Output Voltage High	V _{OH}	V _{CC} ≥ 1.0V, I _{SOURCE} = 1μA	0.8 × V _{CC}			V
		V _{CC} ≥ 1.8V, I _{SOURCE} = 150μA	0.8 × V _{CC}			
		V _{CC} ≥ 2.7V, I _{SOURCE} = 500μA	0.8 × V _{CC}			
		V _{CC} ≥ 4.5V, I _{SOURCE} = 800μA	0.8 × V _{CC}			
RESET Output Voltage Low	V _{OL}	V _{CC} ≥ 1.8V, I _{SINK} = 500μA			0.3	V
		V _{CC} ≥ 2.7V, I _{SINK} = 1.2mA			0.3	
		V _{CC} ≥ 4.5V, I _{SINK} = 3.2mA			0.4	

TYPICAL PERFORMANCE CHARACTERISTICS

$V_{CC} = 5V$, $C_{SRT} = 1500pF$, $T_A = +25^\circ C$, unless otherwise noted.

Supply Current vs. Supply Voltage

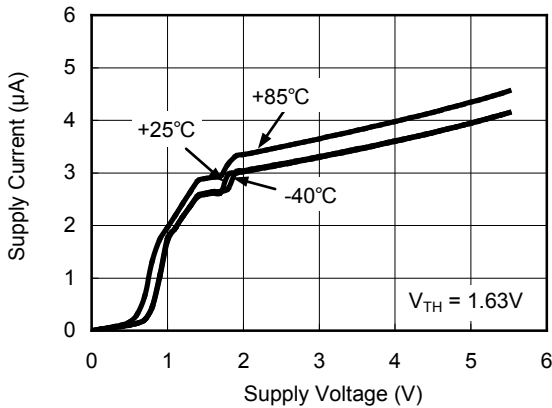

Reset Timeout Period vs. C_{SRT}

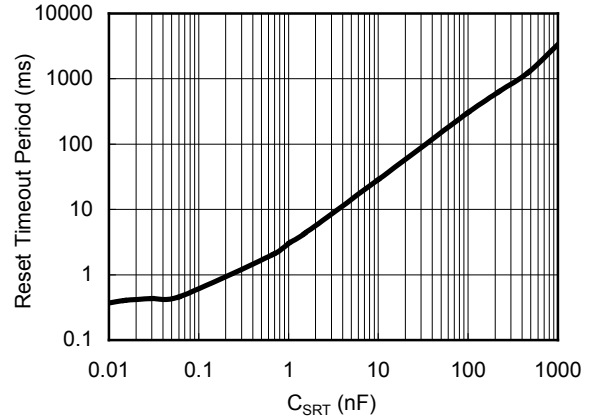

Reset Timeout Period vs. Temperature

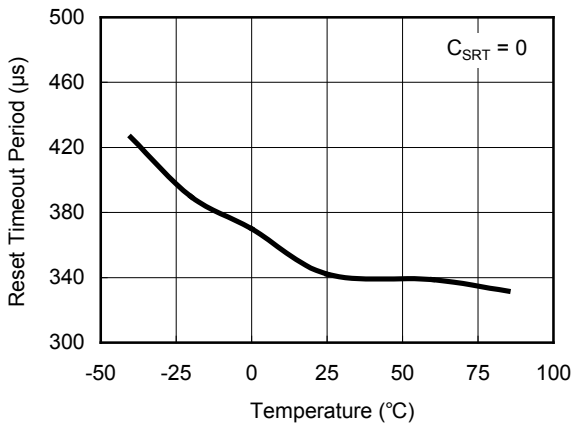

Reset Timeout Period vs. Temperature

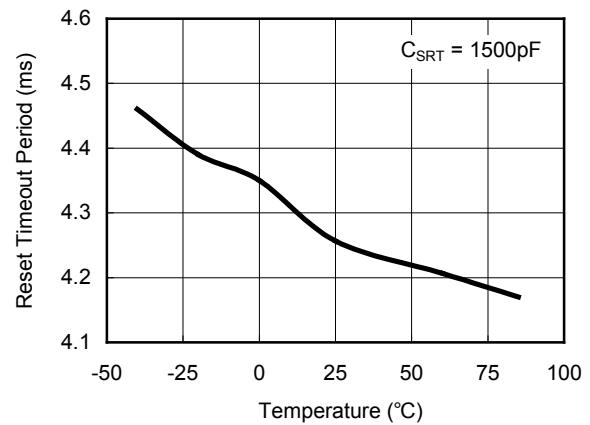

Normalized Reset Threshold vs. Temperature

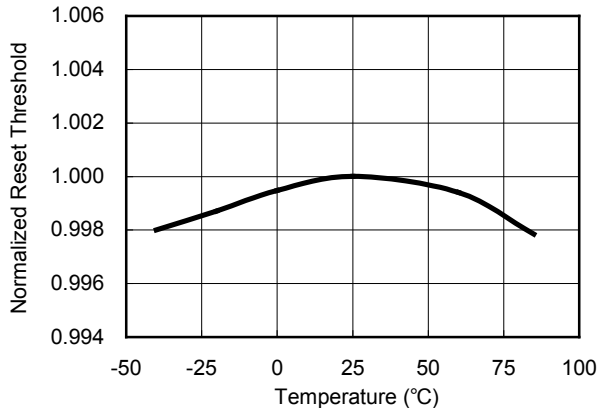

Maximum Transient Duration vs. Reset Threshold Overdrive

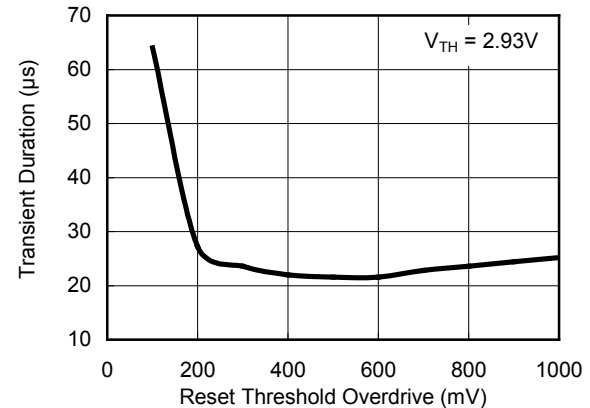

TYPICAL PERFORMANCE CHARACTERISTICS

$V_{CC} = 5V$, $C_{SRT} = 1500pF$, $T_A = +25^{\circ}C$, unless otherwise noted.

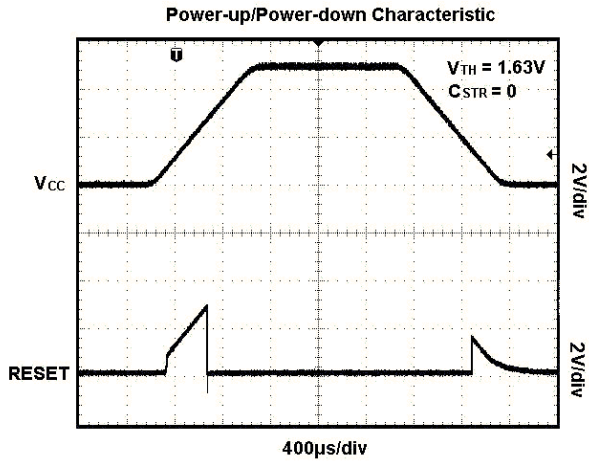

DETAILED DESCRIPTION

Reset Output

The reset output is typically connected to the reset input of a μ P. A μ P's reset input starts or restarts the μ P in a known state. The SGM802 μ P supervisory circuit provides the reset logic to prevent code-execution errors during power-up, power-down, and brownout conditions.

RESET changes from low to high whenever V_{CC} drops below the threshold voltage. Once V_{CC} exceeds the threshold voltage, RESET remains high for the capacitor-adjustable reset timeout period.

This device output is guaranteed valid for $V_{CC} > 1V$.

Operating as a Voltage Detector

The SGM802 can be operated in a voltage detector mode by floating the SRT pin. The reset delay times for V_{CC} rising above or falling below the threshold are not significantly different. The reset output is deasserted smoothly without false pulses.

Selecting a Reset Capacitor

The reset timeout period is adjustable to accommodate a variety of μ P applications. Adjust the reset timeout period (t_{RP}) by connecting a capacitor (C_{SRT}) between SRT and ground. Calculate the reset timeout capacitor as follows:

$$C_{SRT} = (t_{RP} - 340 \times 10^{-6}) / (2.6 \times 10^6)$$

where t_{RP} is in seconds and C_{SRT} is in farads.

The reset delay time is set by a current/capacitor-controlled ramp compared to an internal 0.6V reference. An internal 210nA ramp current source charges the external capacitor. The charge to the capacitor is cleared when a reset condition is detected. Once the reset condition is removed, the voltage on the capacitor ramps according to the formula: $dV/dt = I/C$. The C_{SRT} capacitor must ramp to 0.6V to deassert the reset. C_{SRT} must be a low-leakage (<10nA) type capacitor; ceramic is recommended.

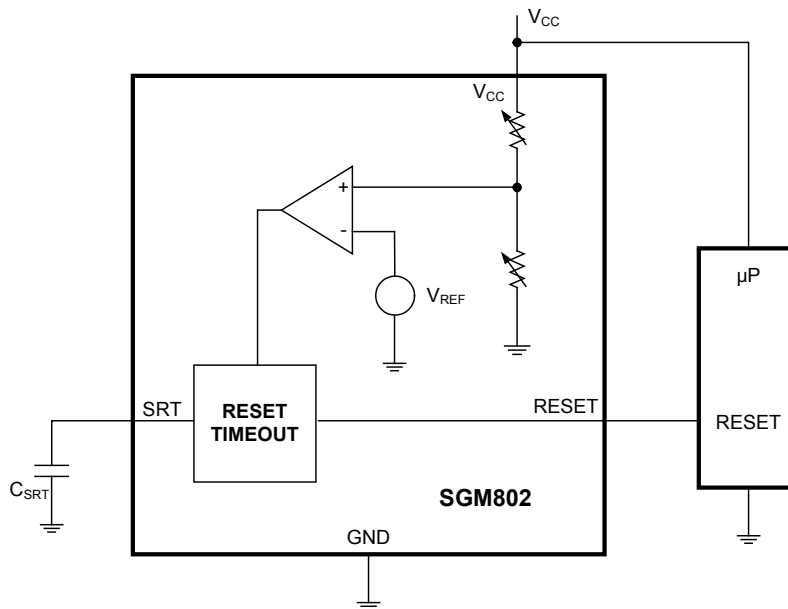

Figure 1. Typical Operating Circuit

APPLICATION INFORMATION

Negative-Going V_{CC} Transients

In addition to issuing a reset to the μ P during power-up, power-down, and brownout conditions, this supervisor is relatively immune to short-duration negative-going transients (glitches). The graph Maximum Transient Duration vs. Reset Threshold Overdrive in the Typical Performance Characteristics shows this relationship.

The area below the curve of the graph is the region in which these devices typically do not generate a reset pulse. This graph was generated using a negative-going pulse applied to V_{CC} , starting above the actual reset threshold (V_{TH}) and ending below it by the magnitude indicated (reset-threshold overdrive). As the magnitude of the transient decreases (further below the reset threshold), the maximum allowable pulse width-decreases. Typically, a V_{CC} transient that goes 100mV below the reset threshold and lasts 50 μ s or less does not cause a reset pulse to be issued.

Ensuring a Valid RESET Down to $V_{CC} = 0$

When V_{CC} falls below 1V, RESET current-sinking (sourcing) capabilities decline drastically.

For applications using the SGM802, a 100k Ω pull up resistor between RESET and V_{CC} holds RESET high when V_{CC} falls below 1V (Figure 2).

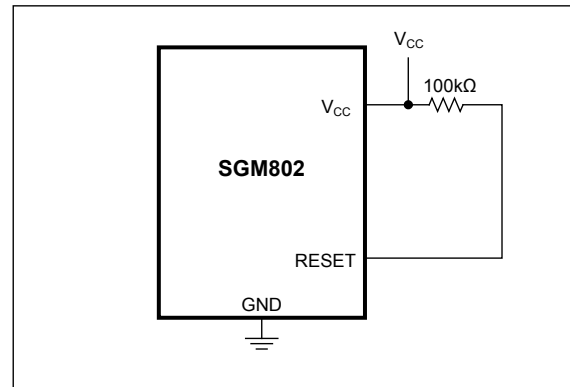

Figure 2. Ensuring RESET Valid to $V_{CC} = 0$

Layout Consideration

SRT is a precise current source. When developing the layout for the application, be careful to minimize board capacitance and leakage currents around this pin. Traces connected to SRT should be kept as short as possible. Traces carrying high-speed digital signals and traces with large voltage potentials should be routed as far from SRT as possible. Leakage current and stray capacitance (e.g., a scope probe) at this pin could cause errors in the reset timeout period. When evaluating these parts, use clean prototype boards to ensure accurate reset periods.

PACKAGE OUTLINE DIMENSIONS

SC70-4 (R)

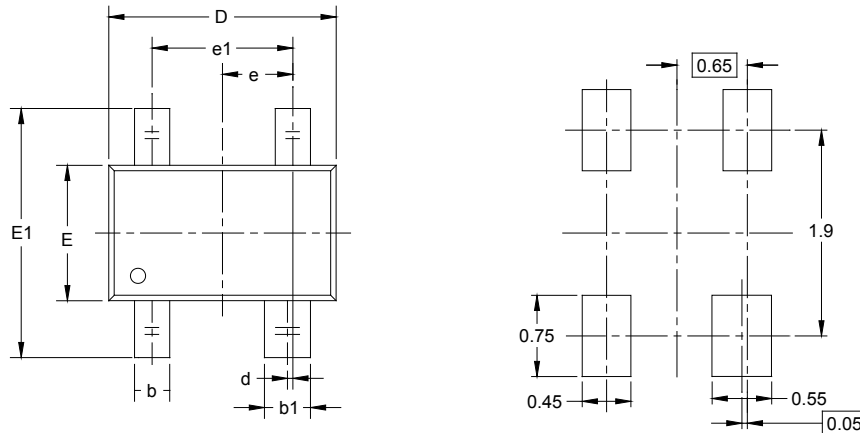

RECOMMENDED LAND PATTERN (Unit: mm)

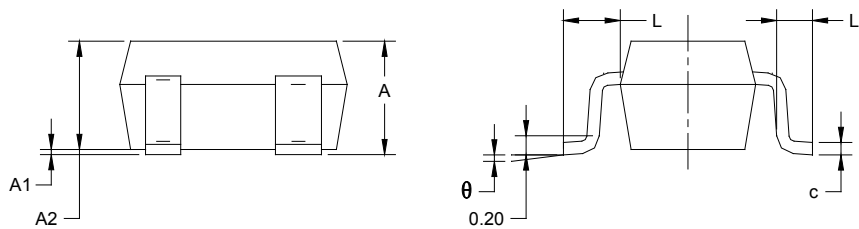

Symbol	Dimensions In Millimeters		Dimensions In Inches	
	MIN	MAX	MIN	MAX
A	0.900	1.100	0.035	0.043
A1	0.000	0.100	0.000	0.004
A2	0.900	1.000	0.035	0.039
b	0.250	0.400	0.010	0.016
b1	0.350	0.500	0.014	0.020
c	0.080	0.150	0.003	0.006
d	0.050TYP		0.002TYP	
D	2.000	2.200	0.079	0.087
E	1.150	1.350	0.045	0.053
E1	2.150	2.450	0.085	0.096
e	0.65 TYP		0.026 TYP	
e1	1.200	1.400	0.047	0.055
L	0.525 REF		0.021 REF	
L1	0.260	0.460	0.010	0.018
θ	0°	8°	0°	8°

PACKAGE OUTLINE DIMENSIONS

SOT-143

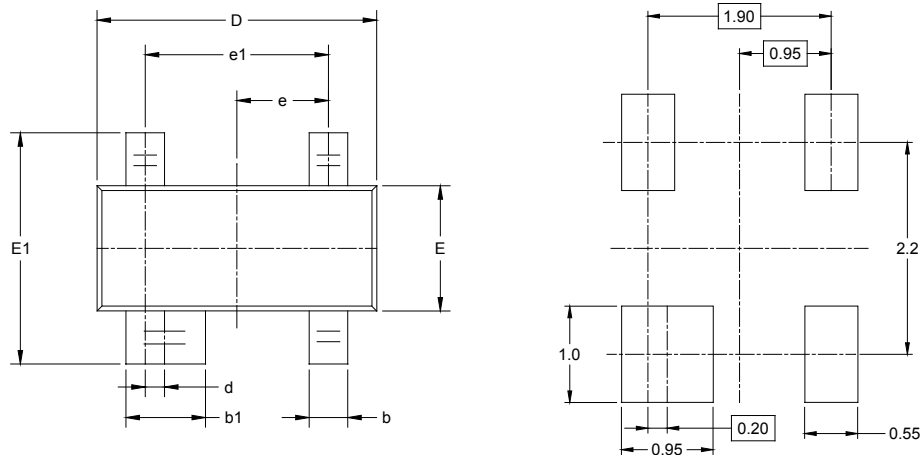

RECOMMENDED LAND PATTERN (Unit: mm)

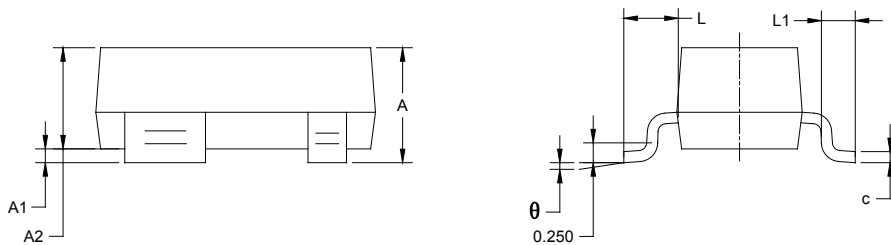

Symbol	Dimensions In Millimeters		Dimensions In Inches	
	MIN	MAX	MIN	MAX
A	0.900	1.150	0.035	0.045
A1	0.000	0.100	0.000	0.004
A2	0.900	1.050	0.035	0.041
b	0.300	0.500	0.012	0.020
b1	0.750	0.900	0.030	0.035
c	0.080	0.150	0.003	0.006
D	2.800	3.000	0.110	0.118
d	0.200 TYP		0.008 TYP	
E	1.200	1.400	0.047	0.055
E1	2.250	2.550	0.089	0.100
e	0.95 TYP		0.037 TYP	
e1	1.800	2.000	0.071	0.079
L	0.55 REF		0.022 REF	
L1	0.300	0.500	0.012	0.020
θ	0°	8°	0°	8°

TAPE AND REEL INFORMATION

REEL DIMENSIONS

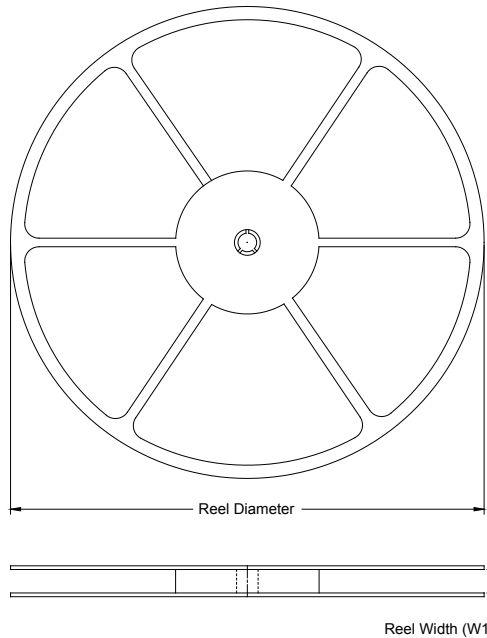

TAPE DIMENSIONS

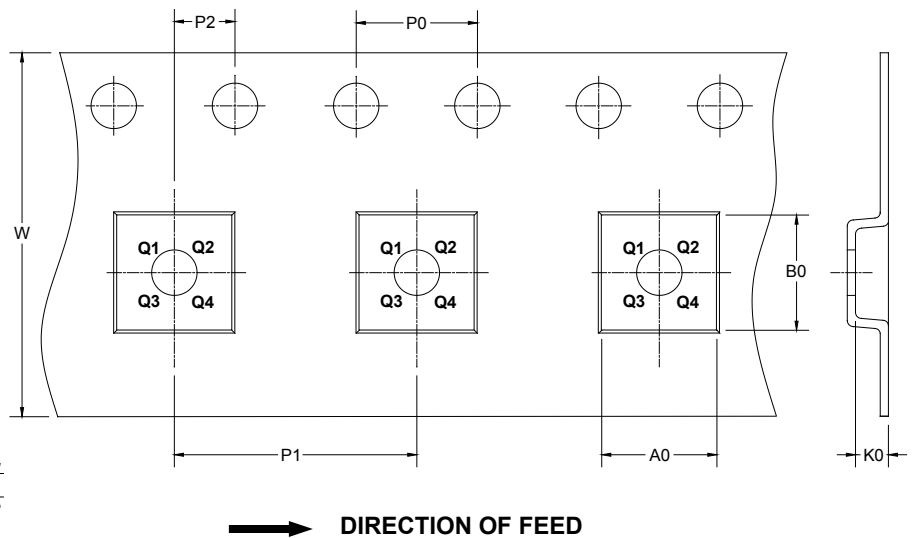

NOTE: The picture is only for reference. Please make the object as the standard.

KEY PARAMETER LIST OF TAPE AND REEL

Package Type	Reel Diameter	Reel Width W1 (mm)	A0 (mm)	B0 (mm)	K0 (mm)	P0 (mm)	P1 (mm)	P2 (mm)	W (mm)	Pin1 Quadrant
SC70-4 (R)	7"	9.5	3.2	2.8	1.3	4.0	4.0	2.0	8.0	Q3
SOT-143	7"	9.5	3.2	2.8	1.3	4.0	4.0	2.0	8.0	Q3

CARTON BOX DIMENSIONS

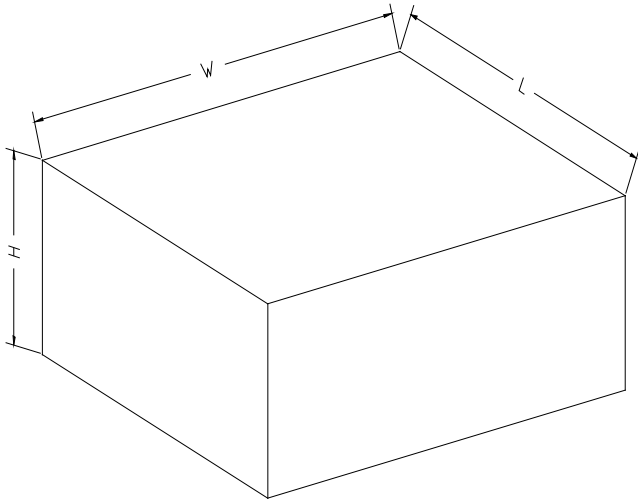

NOTE: The picture is only for reference. Please make the object as the standard.

KEY PARAMETER LIST OF CARTON BOX

Reel Type	Length (mm)	Width (mm)	Height (mm)	Pizza/Carton
7" (Option)	368	227	224	8
7"	442	410	224	18