

FG4000HX-90DS

HIGH POWER INVERTER USE
PRESS PACK TYPE

FG4000HX-90DS



- ITQRM Repetitive controllable on-state current 3000A
- IT(AV) Average on-state current 1200A
- VDRM Repetitive peak off state voltage 4500V
- Anode short type

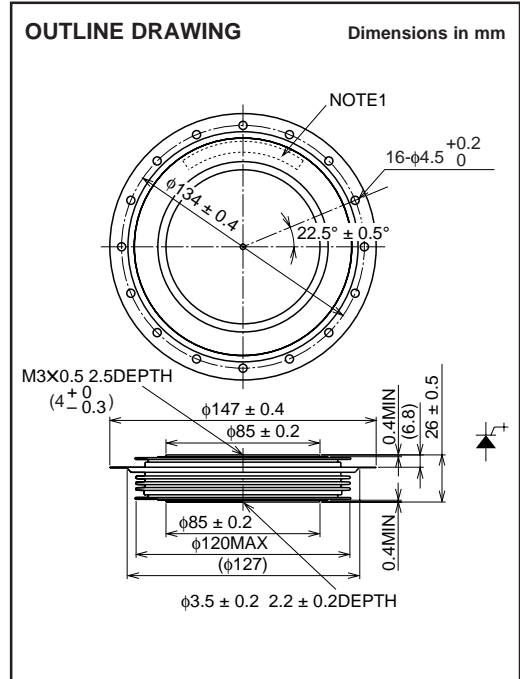

APPLICATION

Inverters, DC choppers, Induction heaters, DC to DC converters.

MAXIMUM RATINGS

Symbol	Parameter	Voltage class		Unit
		90DS		
VRRM	Repetitive peak reverse voltage	19		V
VRSM	Non-repetitive peak reverse voltage	19		V
VR(DC)	DC reverse voltage	19		V
VDRM	Repetitive peak off-state voltage*	4500		V
VDSM	Non-repetitive peak off-state voltage*	4500		V
VD(DC)	DC off-state voltage*	2500		V

* : VGK = -2V

Symbol	Parameter	Conditions	Ratings	Unit
ITQRM	Repetitive controllable on-state current	VDM = 3375V, Cs = 3.0 μ F, Ls = 0.4 μ H, Tj = 25/125°C	3000	A
IT(RMS)	RMS on-state current	Applied for all conduction angles	1880	A
IT(AV)	Average on-state current	f = 60Hz, sinewave $\theta = 180^\circ$, Tf = 78°C	1200	A
ITSM	Surge on-state current	One half cycle at 60Hz, Tj = 125°C	20	kA
I ² t	Current-squared, time integration		1.7 × 10 ⁶	A ² s
di/dt	Critical rate of rise of on-state current	V _D = 2250V, I _{TM} = 3000A, I _{GM} = 100A, Tj = 125°C diG/dt = 50A/ μ s, Cs = 3 μ F, Rs = 5 Ω	500	A/ μ s
VFGM	Peak forward gate voltage		10	V
VRGM	Peak reverse gate voltage		19	V
IFGM	Peak forward gate current		1000	A
IRGM	Peak reverse gate current		4000	A
PFGM	Peak forward gate power dissipation	tw = 20 μ s, f = 60Hz	10	kW
PRGM	Peak reverse gate power dissipation	tw = 30 μ s, f = 60Hz	120	kW
PFG(AV)	Average forward gate power dissipation		200	W
PRG(AV)	Average reverse gate power dissipation		6300	W
Tj	Junction temperature		-40 ~ +125	°C
Tstg	Storage temperature		-40 ~ +150	°C
—	Mounting force required	(Recommended value 47kN)	39 ~ 55	kN
—	Weight	Typical value	1600	g

FG4000HX-90DS

HIGH POWER INVERTER USE
PRESS PACK TYPE

ELECTRICAL CHARACTERISTICS

Symbol	Parameter	Test conditions	Limits			Unit
			Min	Typ	Max	
V _{TM}	On-state voltage	I _T = 3000A, T _j = 125°C	—	—	3.5	V
I _{RRM}	Repetitive peak reverse current	V _{RM} = 19V, T _j = 125°C	—	—	100	mA
I _{DRM}	Repetitive peak off-state current	V _{DM} = 4500V, V _{GK} = -2V, T _j = 125°C	—	—	150	mA
I _{GRM}	Reverse gate current	V _{RG} = 19V, T _j = 125°C	—	—	100	mA
dv/dt	Critical rate of rise of off-state voltage	V _D = 2250V, T _j = 125°C, V _{GK} = -2V (Expo. ware)	1000	—	—	V/μs
t _d	Delay time	I _T = 3000A, V _D = 2250V, I _{GM} = 100A, T _j = 125°C di/dt = 500A/μs, dg/dt = 50A/μs Cs = 3μs, Rs = 5Ω	—	—	3	μs
t _s	Storage time	I _T = 3000A, V _{DM} = 3375V, V _D = 2250V diGQ/dt = 6000A/μs, Cs = 3.0μF, Ls = 0.4μH	—	—	3	μs
I _{GQ}	Peak gate turn-off current	T _j = 125°C	—	—	—	A
I _{GT}	Gate trigger current	DC METHOD : V _D = 24V, R _L = 0.1Ω, T _j = 25°C	—	—	4.0	A
V _{GT}	Gate trigger voltage		—	—	1.5	V
R _{th(j-f)}	Thermal resistance	Junction to fin	—	—	0.01	°C/W

PERFORMANCE CURVES

MAXIMUM ON-STATE CHARACTERISTIC

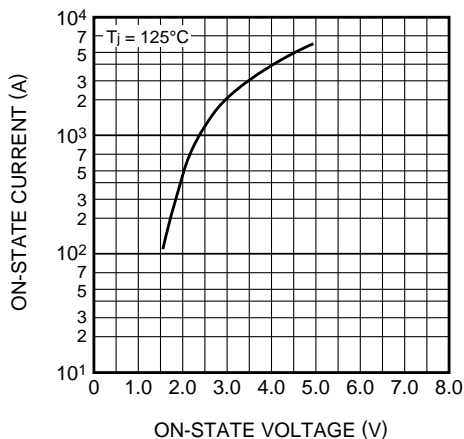

RATED SURGE ON-STATE CURRENT

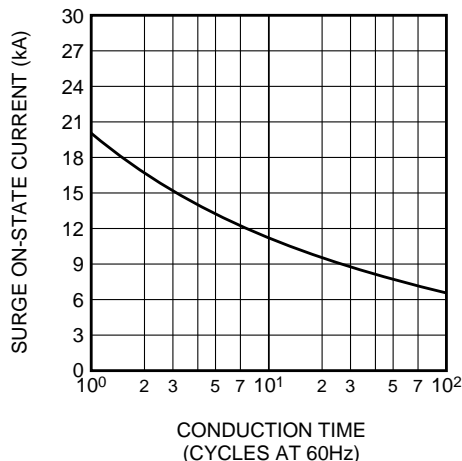

GATE CHARACTERISTICS

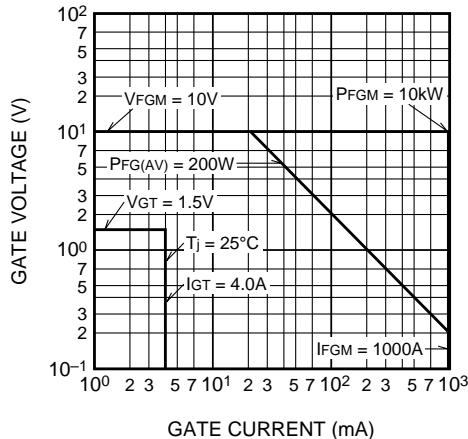

MAXIMUM THERMAL IMPEDANCE CHARACTERISTIC (JUNCTION TO FIN)

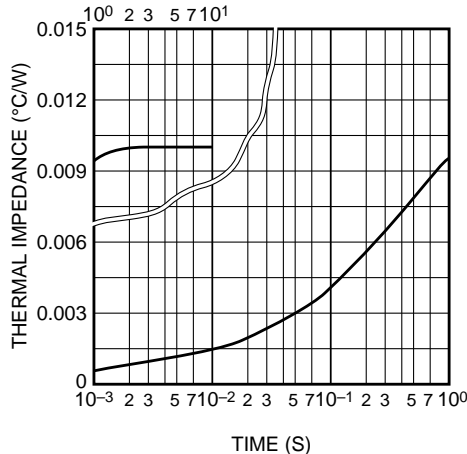

FG4000HX-90DS

HIGH POWER INVERTER USE
PRESS PACK TYPE

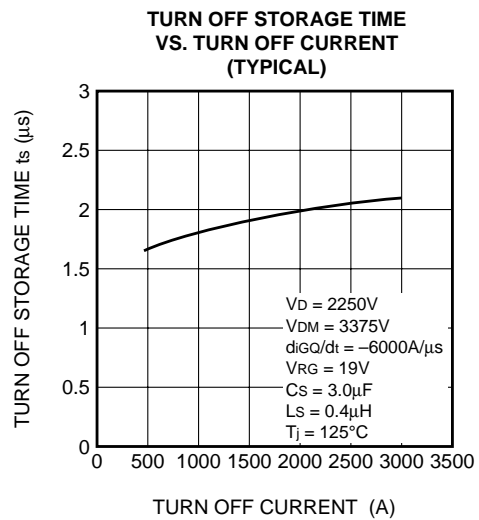
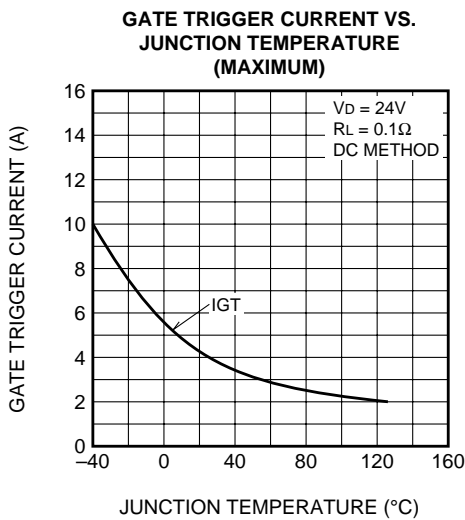
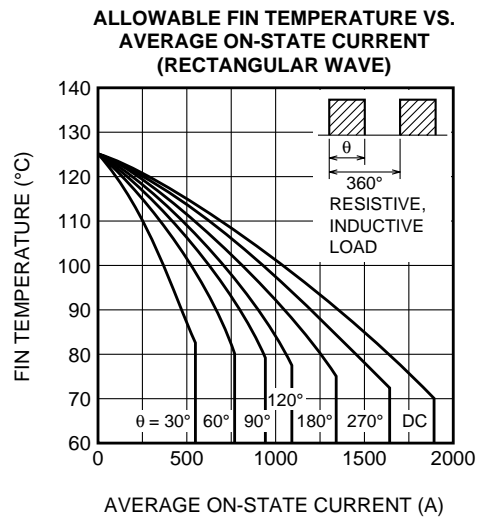
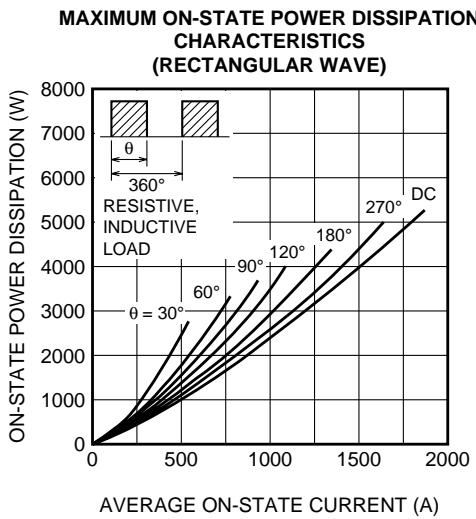
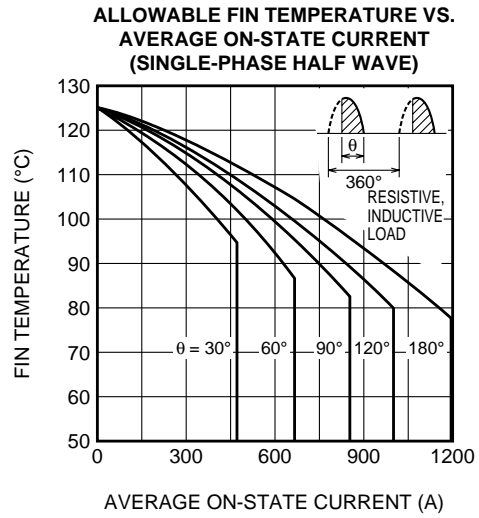
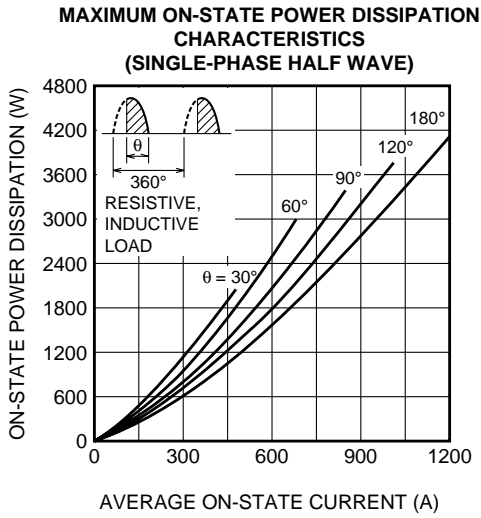

FG4000HX-90DS

HIGH POWER INVERTER USE
PRESS PACK TYPE

TURN ON SWITCHING ENERGY (MAXIMUM)

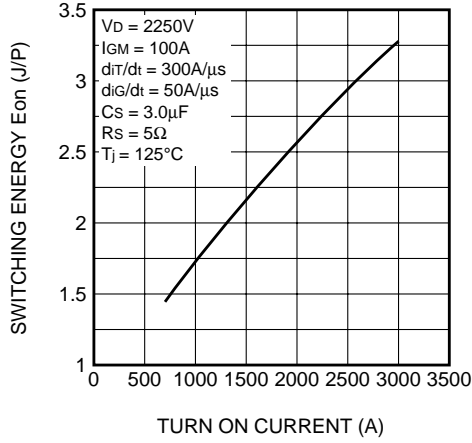

TURN OFF SWITCHING ENERGY (MAXIMUM)

